

# SPARE PART INSTRUCTION

NR. **1.2.3** NAME **Castor fork /wheel**

VERSION 1.0 DATE 05-04-2020 BY Ruben Roumans

PAGE  
**1 of 1**

M8 = 18Nm  
M6 = 10Nm  
M5 = 6Nm  
M4 = 4Nm

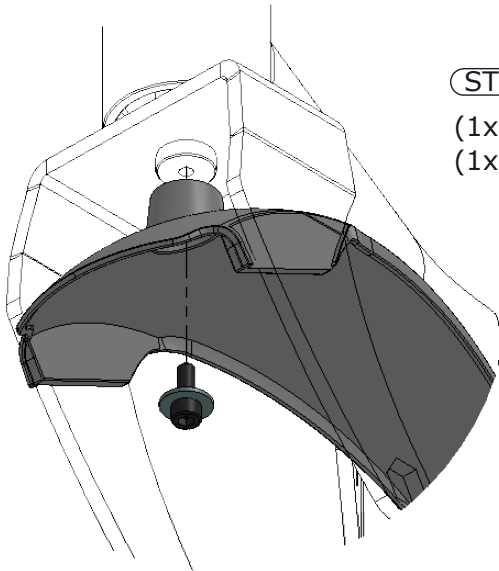

### STEP 1

(1x) M6x16  
(1x) M6 Washer

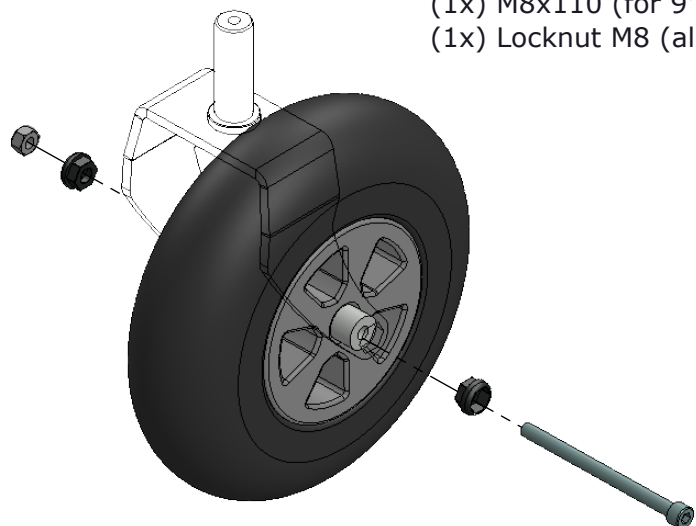

### STEP 2

(1x) M8x75 (for 8')  
(1x) M8x110 (for 9')  
(1x) Locknut M8 (all metal)

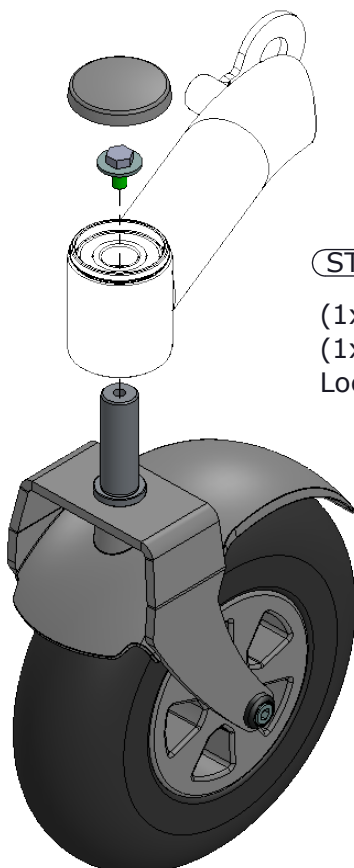

### STEP 3

(1x) M8x16  
(1x) M8 Washer  
Loctite 243